

# 303 Series Load Frames

Rigid two-column high precision hydrostatic fatigue-rated axial load frames for material or component characterization.

BIA West 303 load frames are versatile test systems used for a variety of applications, **from simple monotonic proof tests to highly complex Thermo Mechanical Fatigue (TMF) experiments**. The system can be configured to run standard ASTM tests as well as your unique custom protocols. The load frames are paired with our industry leading controller, hydraulic actuator, manifold, servo valves, and Whisperpak® pump to create a highly accurate and durable test instrument.

The load frame structure is specifically designed to provide **maximum rigidity**. The Series 303 load frames feature 2-column symmetrical construction with a fixed-platen and moveable crosshead on **hydraulic lifts**. On these free-standing units, the actuator is mounted to a casting that can be mounted below the platen with the load cell affixed to the crosshead, or the casting itself can be used as the crosshead, so that the actuator extends from the top. A T-slotted base can add further flexibility for fixturing.

Note that we **also build load frames with polymer bearings** for a more cost-effective solution (see our 302 line) and **larger 4-column frames** (see our model 304 frames). Our 301 series frames are **tabletop units**.

The 303 Series load frames come in standard configurations (below) with **other force combinations and configurations available on request**. All units are delivered fully equipped including a linear actuator, servo valve, service manifold, load cell, and LVDT.

The 303 Series Load Frame can be supplied with a **variety of accessories** such as hydraulic crosshead locks, load cells, grips, furnaces, environmental chambers, and extensometers to meet your specific testing needs.



## Features

- Chrome plated columns. The 303 utilizes two smooth, chrome plated precision ground columns to provide long life and low friction crosshead position changes with high alignment accuracy.
- Hydrostatic bearings. The piston rod is supported on frictionless hydrostatic bearings to provide minimal friction and high side load capacity. This improves test accuracy by reducing distortion due to non-linearities.
- Hydraulic Crosshead controls. The crosshead is vertically adjustable with infinite resolution using hydraulic lifts via a simple control panel. Position of the crosshead is maintained backlash free by torque wrench tightened bolts or optional hydraulic locks. The failsafe design ensures a sudden loss of hydraulic power will not result in any unwanted crosshead motion, and the crosshead will remain locked.
- Accurate alignment. The actuator rod and load cell are concentric within .0015 in (0.038mm) @ 15 inches (380mm) and .002in/ft (0.05mm per 300mm) thereafter.
- Integrated displacement measurement. The linear actuator includes a co-axially mounted LVDT in the piston rod.
- Rigid construction. No intermediate threaded joints or compression joints are utilized, and the load is transmitted directly into the crosshead during testing.
- High quality servohydraulic components. The system is designed using BIA West hydraulics, renowned for providing years of trouble-free operation, and the result of over 40 years of experience.

## Options

- Hydraulic crosshead locks. Hydraulically operated crosshead locks are available on all models
- Vibration isolation mounts. Dynamic testing can produce unwanted vibration that can be transmitted to the laboratory floor. Isolation pads under the load frame help reduce noise and dampen vibrations.
- Safety enclosure. A safety enclosure can be fitted around the test area to protect the operator during destructive testing.
- Actuator sizing. Different actuator displacements and valves are available, as well as custom force ratings. Service Manifolds, servo-valves and hydraulic power supplies are sized based on your application.
- Accessories. Choose from a wide variety of grips, fixtures, extensometers, furnaces, environmental chambers, larger power supplies and various load cell force ratings.

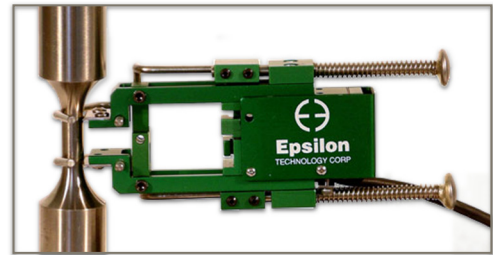

# Base Mount Actuator Specifications

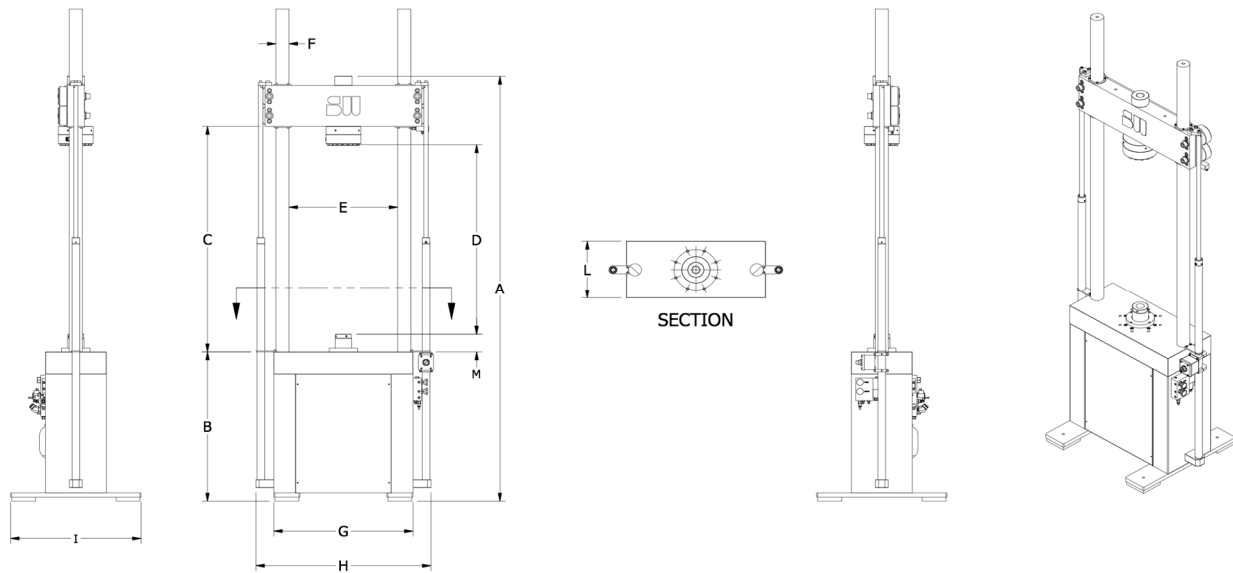

Updated 6/30/2014	Ref.	Model 303.2		Model 303.3		Model 303.4	
		in	cm	in	cm	in	cm
Column Diameter	F	3.0	7.6	3.0	7.6	4.0	10.2
Column Spacing	E	21.0	53.3	25.0	63.5	30.0	76.2
Height (Overall) (1)	A	101.4	257.0	120.4	306.0	141.9	360.0
Max Clearance (1)	C	57.3	145.0	73.3	186.0	91.3	232.0
Min Test Length (1)(2)(3)	D	4.8	12.0	9.8	25.0	14.4	37.0
Max Test Length (1)(2)(3)	D	52.5	133.0	67.7	172.0	83.6	212.0
Platen Height	B	34.4	87.0	34.9	89.0	35.4	90.0
Platen Depth	L	10.0	25.0	13.3	34.0	18.0	46.0
Min Actuator Extension (3)	M	1.3	3.3	1.1	2.7	1.2	3.0
Base Width	G	32.3	82.0	36.8	93.0	44.3	112.0
Width (with lifts)	H	36.8	93.0	41.3	105.0	48.8	124.0
Base Depth	I	24.0	61.0	30.0	76.0	36.0	91.0
Deflection at Rated Load (4)		0.006	0.016	0.015	0.037	0.022	0.055
Stiffness (lbf/in)		3.41E+06		3.77E+06		5.07E+06	
Stiffness (N/mm)		6E+05		7E+05		9E+05	
Weight (lb)		1440		2190		4480	
Weight (kg)		653		993		2032	
Force Rating (kip)		11 or 22		55		110	
Force Rating (kN)		50 or 100		250		500	

- (1) Based on standard column length, optional lengths available
- (2) Based on standard load cell, without alignment fixture, without grips.
- (3) Actuator retracted to end of dynamic stroke.
- (4) At rated load with exposed column length of 29.5 inches for 303.2, 35.5 inches for 303.3 and 50 inches for 303.4. The actuator rod and load cell are concentric within 0.0015 inches @ 15 inches of separation (0.002 in/ft thereafter). Note: Service manifold, servo valves and hydraulic power supplies are sized and selected based on application.

**Specifications subject to change without notice.**

# Crosshead Mount Actuator Specifications

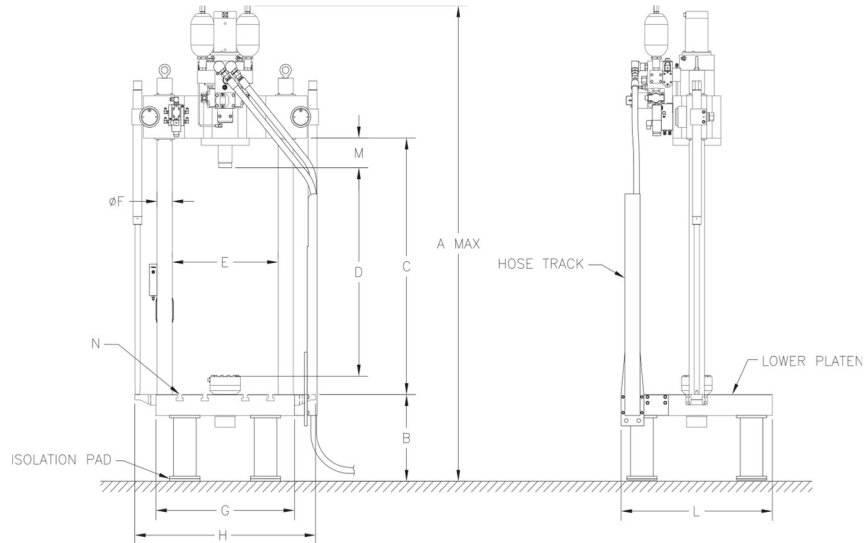

Updated 7/3/2014	Ref.	Model 303.2H		Model 303.3H		Model 303.4H	
		in	cm	in	cm	in	cm
Column Diameter	F	3.0	7.6	3.0	7.6	4.0	10.2
Column Spacing	E	21.0	53.3	25.0	63.5	30.0	76.2
Height (Overall) (1)	A	100.1	254.0	116.8	297.0	137.3	349.0
Max Clearance (1)	C	57.3	145.0	73.3	186.0	91.3	232.0
Min Test Length (1)(2)(3)	D	22.7	58.0	28.4	72.0	33.8	86.0
Max Test Length (1)(2)(3)	D	52.5	133.0	67.7	172.0	83.6	212.0
Platen Height	B	18.0	46.0	19.0	48.0	20.0	51.0
Platen Depth	L	30.0	76.0	48.0	122.0	60.0	152.0
Min Actuator Extension (3)	M	1.3	3.3	1.1	2.7	1.2	3.0
Base Width	G	28.0	71.0	32.5	83.0	40.0	102.0
Width (with lifts)	H	36.3	92.0	40.8	104.0	48.3	123.0
Deflection at Rated Load (4)		0.008	0.020	0.016	0.041	0.026	0.066
Stiffness (lbf/in)		2.8E+06		3.42E+06		4.23E+06	
Stiffness (N/mm)		5E+05		6E+05		7E+05	
Weight (lb)		2100		3700		7000	
Weight (kg)		953		1678		3175	
Force Rating (kip)		11 or 22		55		110	
Force Rating (kN)		50 or 100		250		500	
T-Slot Width (in)	N	0.75		1		1.375	
T-Slot Width (mm)	N	20		24		36	

(1) Based on standard column length, optional lengths available

(2) Based on standard load cell, without alignment fixture, without grips.

(3) Actuator retracted to end of dynamic stroke.

(4) At rated load with exposed column length of 29.5 inches for 303.2H, 35.5 inches for 303.3H and 50 inches for 303.4H.

The actuator rod and load cell are concentric within 0.0015 inches @ 15 inches of separation (0.002 in/ft thereafter).

Note: Service manifold, servo valves and hydraulic power supplies are sized and selected based on application.

**Specifications subject to change without notice.**