

301 Series Load Frames

Rigid two-column fatigue-rated axial tabletop frames for material characterization.

BIA West 301 load frames are versatile test systems used for a variety of applications, **from simple monotonic proof tests, to highly complex Thermo Mechanical Fatigue (TMF) experiments.** The system can be configured to run standard ASTM tests as well as your unique custom protocols. The load frames are paired with our industry leading controller, hydraulic actuator, manifold, servo valves, and pumps to create a highly accurate and durable test instrument.

The load frame structure is specifically designed to provide **maximum rigidity.** The Series 301 features 2-column symmetrical construction with a fixed-platen and moveable crosshead on **hydraulic lifts**¹. The actuator is mounted in the crosshead with the load cell affixed to the platen.

Note that **tabletop axial torsion load frames are also available** (pictured). We also build a full line of floor-standing units.

The 301 Series tabletop load frames come in standard configurations (below) with **other force combinations and configurations available on request.** All units are delivered fully equipped including a linear actuator, servo valve, service manifold, load cell, and LVDT.

The 301 Series Load Frame can be supplied with a **variety of accessories** such as hydraulic crosshead locks, load cells, grips, furnaces, environmental chambers, and extensometers to meet your specific testing needs.

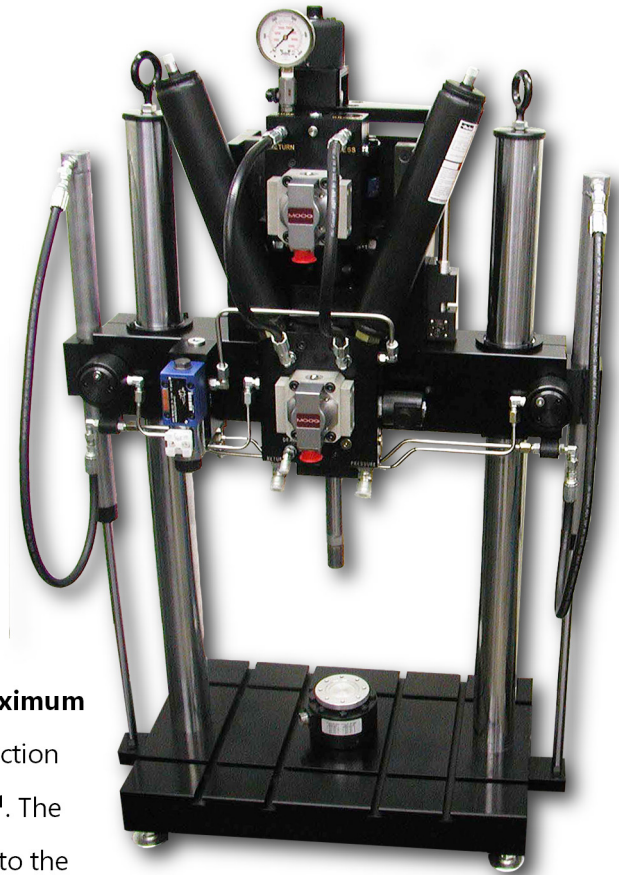

¹ Hydraulic lifts are not standard on the 301.1 series frames

Features

- Chrome plated columns. The 301 utilizes two smooth, chrome plated precision ground columns to provide long life and low friction crosshead position changes with high alignment accuracy.
- Hydraulic Crosshead controls (301.2 and 301.3). The crosshead is vertically adjustable with infinite resolution using hydraulic lifts via a simple control panel. Position of the crosshead is maintained backlash free by torque wrench tightened bolts or optional hydraulic locks. The failsafe design ensures a sudden loss of hydraulic power will not result in any unwanted crosshead motion, and the crosshead will remain locked.
- Accurate alignment. The actuator rod and load cell are concentric within .0015 in (0.038mm) @ 15 inches (380mm) and .002in/ft (0.05mm per 300mm) thereafter.
- Integrated displacement measurement. The linear actuator includes a co-axially mounted LVDT in the piston rod.
- Rigid construction. No intermediate threaded joints or compression joints are utilized and the load is transmitted directly into the crosshead during testing.
- High quality servo hydraulic components. The system is designed using BIA West hydraulics, renowned for providing years of trouble-free operation, and the result of over 40 years of experience.

Options

- Hydraulic crosshead locks. Hydraulically operated crosshead locks are available on all models
- Vibration isolation mounts. Dynamic testing can produce unwanted vibration that can be transmitted to the laboratory table. Isolation pads under the load frame help reduce noise and dampen vibrations.
- Safety enclosure. A safety enclosure can be fitted around the test area to protect the operator during destructive testing.
- Actuator sizing. Different actuator displacements and valves are available, as well as custom force ratings. Service Manifolds, servo-valves and hydraulic power supplies are sized based on your application.
- Accessories. Choose from a wide variety of grips, fixtures, extensometers, furnaces, environmental chambers, larger power supplies and various load cell force ratings.

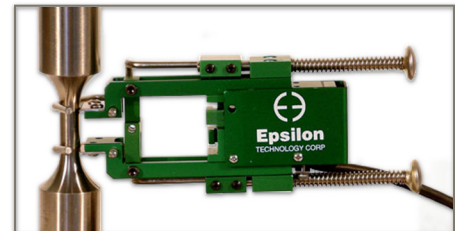

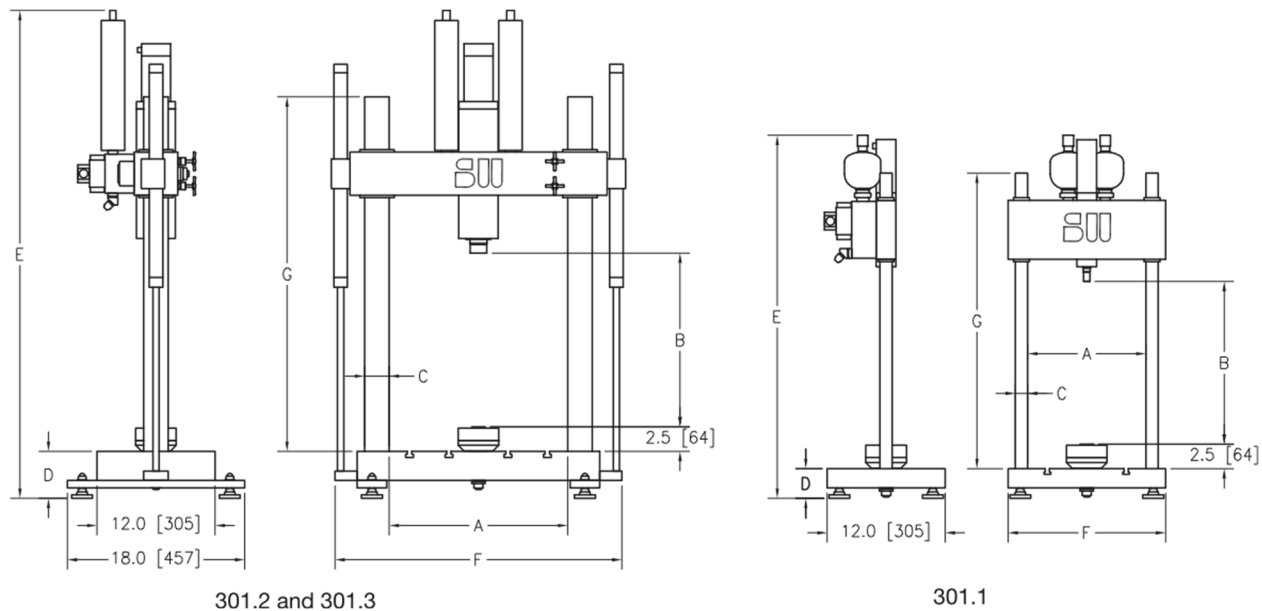

Specifications

		301.1		301.2		301.3	
Force		1.0 kip~1.5 kip	4.44 kN~6.66 kN	1.1 kip~2.2 kip	4.88 kN~9.77kN	3.3 kip~5.5 kip	14.65 kN~24.42kN
Rod Dia		0.75 in	1.90 cm	1.12 in	2.86 cm	1.75 in	4.44 cm
Actuator Area		0.34 in ² ~0.55 in ²	2.19 cm ²	0.37 in ² ~0.77 in ²	2.39 cm ²	1.14 in ² ~2.0 in ²	7.35 cm ²
Stroke (standard)		4.00 in	10.16 cm	4.00 in	10.16 cm	4.00 in	10.16 cm
Column Work Space	A	12.00 in	30.48 cm	16.00 in	40.64 cm	18.13 in	46.04 cm
Work Space Maximum*	B	18.75 in	47.63 cm	24.25 in	61.60 cm	39.13 in	99.39 cm
Column Dia	C	1.25 in	3.18 cm	2.00 in	5.08 cm	2.50 in	6.35 cm
Platen Height	D	2.50 in	6.35 cm	3.75 in	9.52 cm	4.25 in	10.80 cm
Overall Height Maximum	E	41.10 in	104.40 cm	58.13 in	147.65 cm	66.13 in	168.00 cm
Overall Width	F	16.00 in	40.64 cm	25.50 in	64.77 cm	29.13 in	73.98 cm
Column Length**	G	30.00 in	76.20 cm	36.00 in	91.44 cm	48.00 in	121.92 cm
Stiffness***		8.08E+05 lb/in	1.41E+06 N/cm	8.06E+05 lb/in	1.41E+06 N/cm	9.01E+05 lb/in	1.58E+06 N/cm
Weight		160 lb	73 kg	280 lb	130 kg	425 lb	200 kg

* workspace is distance from load cell face to retracted actuator rod

** standard column length, extended lengths available

*** exposed column length: 301.1: 18in (45.72cm); 301.2: 24in (60.96cm); 301.3: 24in (60.96cm)

The load cell can be mounted to the actuator piston rod or the platen

The actuator rod and load cell are concentric within 0.0015 in (0.038 mm) @ 15 in (38.1 cm) of separation and 0.002 in/ft (0.164 mm/m) thereafter.

Specifications subject to change without notice.